

EATON

Powerware

Powerware® Hot Sync™

Paralleling Technology

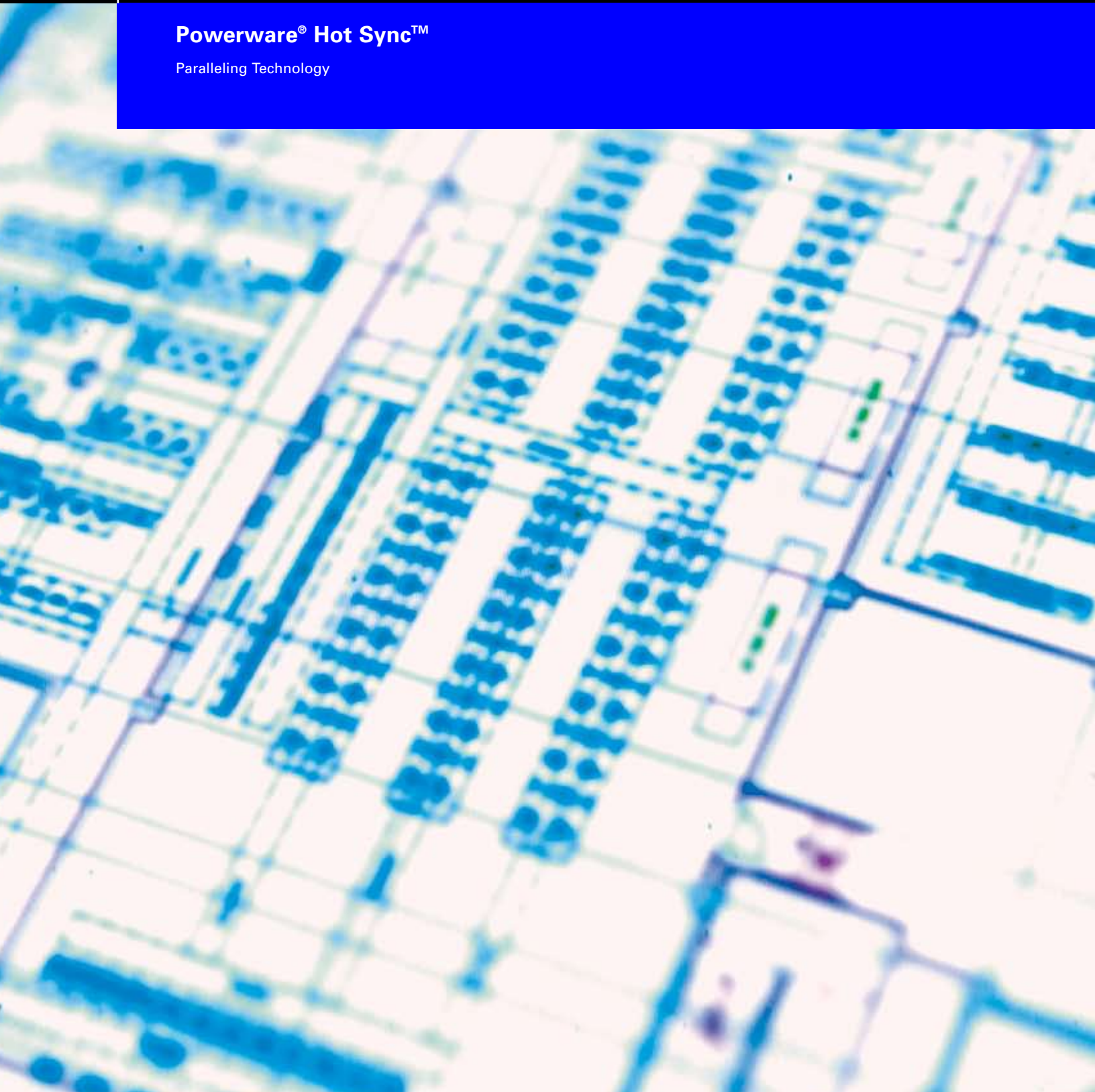

Powerware Hot Sync – The Culmination of Power Reliability

Automatic Load Sharing

In an optimum parallel configuration, the UPS modules must share the load equally. When the critical load is shared between the modules, there should be no transfer time in shifting the load from one module to the other, should a module go offline for any reason.

In a traditional parallel UPS configuration, load sharing requires communications wiring between the modules, which introduces a single point-of-failure. If any part of the communication link fails, so does the system. Powerware Hot Sync technology eliminates the necessity for inter-module communication, providing true wireless paralleling for the first time.

The load share control algorithms maintain synchronization and load balance by constantly making minute adjustments to variations in the output power requirements. The modules conform to demand and are not in conflict with each other for the load.

There are many other parameters that must be addressed to effectively and seamlessly share the load between paralleled modules. The load sharing algorithm in Powerware Hot Sync addresses these considerations, including:

- Load sharing while synchronized to an alternate source
- Power backfeed under imperfect sharing at light or no load
- Power backfeed with 100% load removal
- Loss of synchronizing reference by some but not all modules
- Oscillation of alternate source frequency
- Independent judgment of alternate source availability

All of these factors will affect the operation of the load share function and will frequently conflict with one another. A careful selection of priority and gain is necessary so that the action taken is the one most beneficial to the mission. For example: if one module in a two module redundant system loses information of the alternate “sync” source, the best action is to shed all load to the other module so that the system will remain “in sync” with that source, maintaining its redundancy. If there are three or more modules, the exact opposite action is most beneficial.

Because a one degree difference in phase angle between two modules results in a fifty percent load imbalance, the Powerware Hot Sync algorithm automatically compensates to provide exactly what is needed to share the load equally. Such precise load share control is possible because the Powerware 9315, 9355 and 9390 UPSs deploy a digital signal processing technique known as direct digital synthesis to control inverter frequency.

Selective Tripping

In addition to enabling precise load sharing, Powerware Hot Sync enables a module to employ a unique selective tripping approach. That is, each module need only look at itself to see if it has failed. Without relying on communication links between the modules, there are no time lapses between the time a failure occurs and the time the module is removed from the critical bus.

In a conventional paralleled system, a faulty module is identified by the system bypass. Though most module failures are benign, a failed inverter IGBT may appear as a fault on the critical bus. For this type of failure, it is essential that the failure be quickly identified and the failed module be removed from the critical bus. Because it doesn't require inter-module communication, a failure such as this in a Powerware Hot Sync system is seamlessly compensated for, with the failed module removed instantaneously from the critical bus.

The method used is really quite straightforward. Each module keeps a running record of the voltage and current waveforms for the last cycle and continually compares the present waveforms with the previously recorded waveforms. The difference in voltage times the difference in current for each phase is determined and summed into a single value. This sum is always positive for a faulted module and always negative for a good unit. The result is that the “selective trip” detects the fault before the typical hardware sensors could detect a problem. Unlike competing systems, this prevents the system from going to bypass and protects the critical load from non-conditioned utility power.

Powerware Hot Sync-Capacity (40 - 750 kVA modules)

Parallel for Capacity

Businesses of all sizes need to protect their critical information, transactions and infrastructure. This, along with the growth of mega-data centers, telecommunication switching centers and technology-dependent organizations has created a trend to centralize power management, as well as established the need for flexible power solutions with

the capability of growing to meet changing power demands. With Powerware Hot Sync-Capacity systems, modules are added in parallel to increase overall system capacity.

Powerware Hot Sync-Capacity configurations are completely scalable, with the added benefits of selective tripping, automatic load sharing and synchronization.

These “parallel for capacity” systems feature built-in intelligence that enables them to automatically recognize the customer’s need for capacity and/or redundancy, allowing N+1, N+2, or even N+3 redundancy, depending on the load. This advanced capability is necessary to maximize availability for large load applications in data centers, server farms, ISPs, ISEs and facilities.

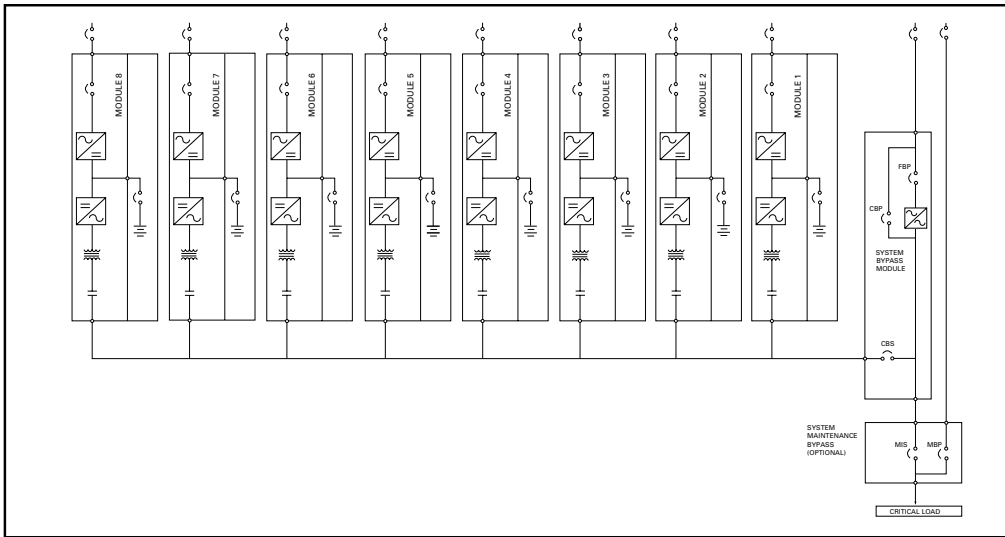

Typical Powerware 9315 200 to 750 kVA Hot Sync Capacity Application

Features & Benefits:

- A system bypass module (SBM) features a system-level bypass for maintenance, fault clearing and emergency conditions, ensuring that the protected load is never at risk
- SBM micro controller-based logic maximizes reliability by reducing component count
- Two fully redundant module monitoring networks provide system-level metering & alarm information to the SBM
- The SBM monitor panel features the same detailed information that is available on the module monitor panel
- Common or separate module battery string configurations are available to enable flexible system configuration for 9315-based systems.
- Field-growth capability of up to 8* modules lets the system expand to meet increased power demands

*4 modules maximum for the Powerware 9355

Powerware Hot Sync-Redundant (40 - 750 kVA modules)

Parallel for Redundancy

A parallel redundant UPS solution increases reliability and maximizes availability. With any type of failure in any module, the critical load is still protected. Powerware Hot Sync-Redundant's unique approach goes further by adding redundant bypass sources, eliminating critical communication wires, and utilizing two separate inputs (the modules are only tied together at their outputs). Because the modules monitor themselves for failure, a Powerware Hot Sync-Redundant system ensures the critical bus remains supported on conditioned power even if one of the modules fails.

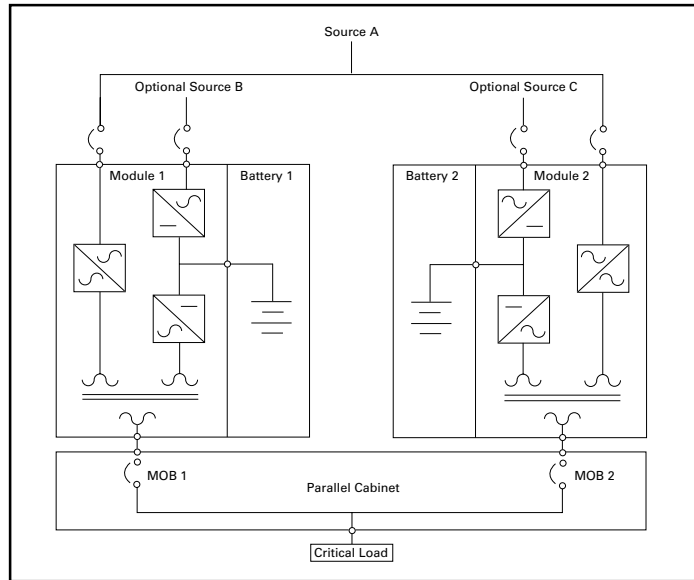

Typical Powerware 10 to 500 kVA Hot Sync Redundant Application

Features & Benefits:

- In a Powerware Hot Sync system, each module features an internal emergency bypass circuit, with two parallel bypass paths. The system provides fault clearing current rated at twice the single module fault clearing current rating, and bypass redundancy. The combination of these features increases overall system reliability and availability.
- The parallel cabinet allows either module to be completely isolated from the critical bus for service while the critical load remains energized with protected power. The module output breakers (MOB) also provide output wiring protection.
- Following any module maintenance action, where a module is isolated from the critical bus by opening a MOB, an indicator light* is illuminated when it is okay to close the MOB. This eliminates the potential of operator error.
- Accommodates separate or common battery configurations, increasing the flexibility of the overall solution.

*Optional

Powerware Hot Sync

Reliability by Design

The constant availability of your critical systems depends on your power management system providing optimal performance, regardless of conditions. And while reliable UPS technology is a good front line of defense, maximum reliability comes with redundancy. Powerware Hot Sync combines the proven reliability of the Powerware 9315, 9355 and 9390 UPS families with a patented paralleling technique. With its high-speed digital signal processing design, Powerware Hot Sync enables paralleling for redundancy or capacity with no inter-module communication.

Each UPS module only needs to monitor its own output to remain in complete synchronization with the other modules.

Two objectives must be accomplished when two or more UPSs are operated in parallel for capacity and redundancy: load sharing and selective tripping. There are also two primary considerations for reliability: the degree of autonomy and the complexity of implementation. Powerware Hot Sync technology combines digital signal processing and an advanced control algorithm to provide automatic load sharing and selective tripping

in a parallel UPS system, as well as complete autonomy of the modules and a skillfully simple implementation. There are many design features in a Powerware Hot Sync paralleled system, and all increase reliability and flexibility:

- Unlike other paralleling techniques, there is no system-level single point-of-failure
- Powerware Hot Sync systems are capable of paralleling for both redundancy and capacity
- By using a peer configuration, as opposed to a “master-slave” configuration, Powerware Hot Sync ensures that each module is operating independently

- No added circuitry or components are required to be “switched in” to operate in parallel

Powerware Hot Sync is field-proven, with thousands of systems installed around the world. Organizations depending on Powerware Hot Sync include:

- E*Trade
- CitiBank
- MFN (formerly Above.net)
- Lucent Technologies
- Fidelity Investments
- New York Stock Exchange

Parallel Architecture	Autonomy	Circuit Complexity	System Wiring	Integration
Master Control	Many Failure Modes	Negotiation needed for Multi-Module	Critical	Extrinsic
Master Sync	PLL buffer dependency	Master clock dependency	Critical	Intrinsic
Load Share Loop	Passive loop buffer dependency	Vector Sum dependency	Critical	Intrinsic
Powerware Hot Sync	Absolute	None	None	Intrinsic

The Powerware Hot Sync Difference

The modules using Powerware Hot Sync are completely autonomous. The only thing common among them is the critical output power bus. Since the Hot Sync parallel control is built into the firmware, no additional hardware is required to ensure synchronization of the UPS modules. This type of control makes it more reliable than traditional paralleling techniques, as shown in the table above. Because the solution is implemented intrinsically, and Powerware

Hot Sync is always active, the modules do not need to know whether or not they are even in parallel.

Using this approach to paralleling for redundancy and capacity, Powerware Hot Sync addresses the inherent drawbacks of traditional configurations. By eliminating communication wiring and added circuitry between the modules, and employing its unique load share and selective tripping methods, Powerware Hot Sync provides a proven path to maximum reliability and system availability.

Physical Dimensions, Weights and Specifications

Powerware Hot Sync - Redundant

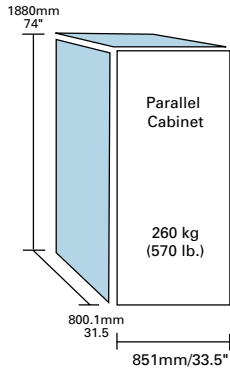

Powerware Hot Sync - Capacity

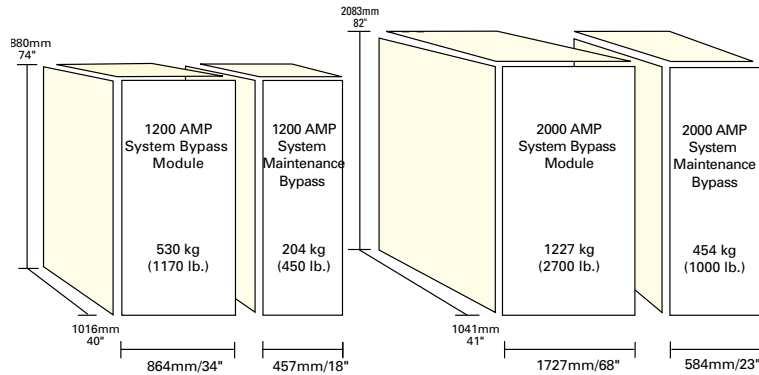

*Note: Powerware 9315 configuration shown. Shipping pallet and packaging adds 50 to 300 lb. per shipping unit.

Environmental Specifications

Ambient Temperature:	0°C to +40°C
Storage:	-20°C to +70°C
Relative Humidity:	5-95% non-condensing
Altitude:	1500 meters (5000 ft.) at 40°C ambient temperature without load derating
Audible Noise:	At 1 meter; in accordance with ISO 7779: - Powerware 9390 40-160 modules: less than 65 dBA - Powerware 9315 200-300 modules: less than 69 dBA - Powerware 9315 400-500 modules: less than 72 dBA - Powerware 9315 625-750 modules: less than 75 dBA

Input Specifications

Voltage Range:	Refer to product data sheets
Frequency Range:	(60 Hz) 57-63 Hz; (50 Hz) 47-53 Hz
Surge Protection:	Meets ANSI C62.41, Category A & B, EN 50091-2 and EN 50082-2
Power Factor:	0.95 typical at full load with input filter. 0.99 for 9355 and 9390
Input Current Distortion with Input Filter:	less than 7% for 9315 - 200 thru 500 less than 5% for 9315 - 625 thru 750, all 9390 and 9355
Powerware 9390 (no input filter required):	less than 4.5%

Output Specifications

Voltage THD:	Less than 5% (100% non-linear load with 3:1 crest factor); less than 3% (100% linear load)
Voltage Regulation:	Better than ±1%
Transient Response:	Less than 5% for 100% load step; full recovery within 1 cycle
Frequency:	(Free Run) ±0.005 Hz
Frequency Sync Range:	±0.5 Hz
Frequency Slew Rate:	1 Hz/second maximum
Output Power Factor Rating	- 9315 0.8 lagging to 0.9 leading without load derating - 9390 0.9 lagging to 0.9 leading without load derating

Safety

UL1778 Listed
CUL CAN/CSA C22.2 NO.107.1-M95 Listed
EN 50091-1
Selectable DC ground fault detection capability (9315 only)



PowerChain
Management™
Solutions

UNITED STATES
8609 Six Forks Road
Raleigh, NC 27615 U.S.A.
Toll Free: 1.800.356.5794
or 919.872.3020

www.powerware.com

CANADA
Ontario: 416.798.0112
Toll free: 1.800.461.9166

LATIN AMERICA
Argentina: 54.11.4343.6323
Brazil: 55.11.3616.8500
México: 52.55.5488.5252

EUROPE/MIDDLE EAST/AFRICA
Denmark: 45.3686.7910
Finland: 358.94.52.661
France: 33.1.6012.7400
Germany: 49.7841.666.0
Italy: 39.02.66.04.05.40
Norway: 47.23.03.65.50
Sweden: 46.8.598.940.00
United Kingdom: 44.1753.608.700

ASIA PACIFIC
Australia/NZ: 61.2.9878.5000
China: 86.21.6361.5599
HK/Korea/Taiwan: 852.2745.6682
India: 91.11.2649.9414 to 18
Singapore/SEA: 65.6825.1668

Powerware and Powerware Hot Sync are trade names, trademarks and/or service marks of Eaton Electrical Inc. All other trademarks are property of their respective owners.

EATON

Powerware

© 2006 Eaton Corporation
All Rights Reserved
Printed in USA
PLS03FYA
October 2006