

POWER DISTRIBUTION UNIT: POWERPAK RPP SERIES

ADVANCED POWER DISTRIBUTION SYSTEMS

WIN THE RACE FOR SPACE & POWER The drive for more power in less space at the server cabinet level continues. PDI's RPP complements this change by offering the most options available in this free-standing 2' x 2' distribution enclosure. Although your PDUs may still be able to handle the power demands of your growing facility, they may not have room for expansion. PDI's Remote Power Panel (RPP) helps you win "the race for space and power" by providing the added pole "space" in a variety of "power" set ups to meet your distribution needs in a small footprint.

In the space of one floor tile, the RPP allows you to effectively use all of your existing capacity before investing in additional distribution. The RPP can pack in dual feeds, up to 168 breakers, and Branch Circuit Monitoring with local monitoring in the 2' x 2' floor tile. The RPP is fed by any standard subfeed circuit breaker of a PDU or 208V distribution board.

SIMPLIFIED EXPANSION

- Reduces the length of cable runs between your PDU and the individual loads
- Optimizes usable floor space
- Simplifies server consolidation plans
- Meets the growth demands of dual cord equipment
- Retrofits to any existing distribution system
- Minimizes your investment risk today by allowing for incremental expansion of your future facility
- Unobstructed wiring access for ease of installation

FLEXIBLE PACKAGING Designed in an aesthetically pleasing cabinet to match the high-tech look of today's computer centers, the RPP's flexible configuration options allow it to grow with your facility. The RPP can function as a stand alone device or as part of an extensive distribution system. You can choose a single input device or dual power feeds to satisfy system redundancy and maintenance requirements. All RPP designs can be packaged to allow



for system expansion without interruption to your loads. Each unit can be equipped with any custom monitoring package you require for your system.

ASSURED PERFORMANCE PDI's complete line of PowerPak technology has long delivered superior performance and protection for your computer systems and equipment. The newest member of the family, the RPP Series product line, allows for flexible expansion of your computer room and reflects PDI's many years of experience in the power quality and distribution industry.

PDI SERVICE AND SUPPORT After your equipment has been installed, call on the PDI service team for 24 - 7 support. Our industry best sales and service team will stay with you from the design of your system through the life of your data center.

POWER DISTRIBUTION UNIT: POWERPAK RPP

SPECIFICATIONS

RATINGS

- Input: 225 amp, 240 volt
- Input: 3-phase, 4 wire plus ground
- Input/Output Voltage @ 60 Hz: 208/120 Volts (consult factory for other ratings)

FEATURES

- 3 pole, 225 amp, 240 volt rated input molded case switch
- Up to four (4) 42 pole distribution panelboards
- Oversized neutral for non-linear loads
- Single point isolated ground (optional)
- Single point equipment ground
- UL Listed

ENCLOSURE

- Compact footprint measuring 24" wide x 24" deep
- Freestanding enclosure
- Removable top, side and rear panels
- Keyed door lock
- Full front inner hinged panelboard cover
- Suitable for top or bottom entry
- CE Listed cabinet
- Vision panels enable visual inspection of breakers without unlocking the cabinet

POWERPAK RPP SERIES OPTIONS

MISSION CRITICAL RPP Order the customer-designed RPP with PDI's unique dual-feed set up, branch circuit monitoring, and camlok connections which allow for maintenance and load bank testing without further coordination and without having to migrate your loads.

LINE & MATCH RPP FOR SERVER CABINETS Get PDI's unsurpassed options for the distribution in a line and match cabinet that fits into your server rack rows. This 38" deep unit will accent the look of your existing cabinets.

BRANCH CIRCUIT MONITORING SYSTEM Choose between the current only version and the voltage version. PDI's patented system allows your site manager to manage loads down to the branch circuit level. See the PDI BCMS brochure for specific differences.

Add a local monitor to your RPP for the best of both worlds – remote management via SNMP or Modbus and local management/reporting of critical measures from your breakers.

BRANCH CIRCUIT BREAKERS Plug-in or bolt-on circuit breakers for individual circuit distribution. Available in a variety of configurations, order factory installed in your RPPs and save time and money.

MAIN INPUT CIRCUIT BREAKER The main input circuit breaker replaces the standard input molded case switch.

TRANSIENT SUPPRESSION NETWORK (TSN) An integrated system designed and engineered to meet ANSI/IEEE category C standards for transient voltages and surge currents.

UL LISTED POWER CABLES PDI's UL listed computer power cables are designed and tested to ensure reliability and proper grounding in a flexible, steel conduit complete with a copper shield wound into the conduit itself. Available in a variety of configurations, order with your RPPs and meet your job site schedule easily.

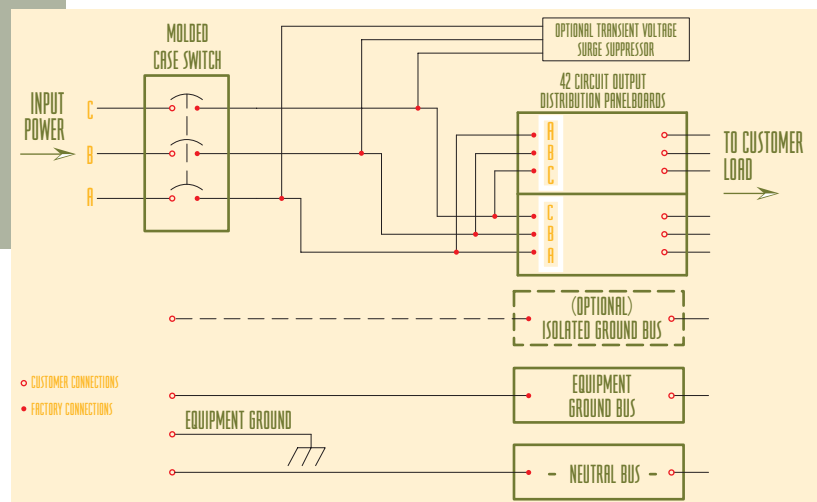

PDI

creating the perfect wave

Power Distribution, Inc.
4200 Oakleys Court
Richmond, VA 23223
800.225.4838
804.737.1703 fax
web site: www.pdicorp.com

25 years